

DELM-FP-01 Double valve deluge foam skid

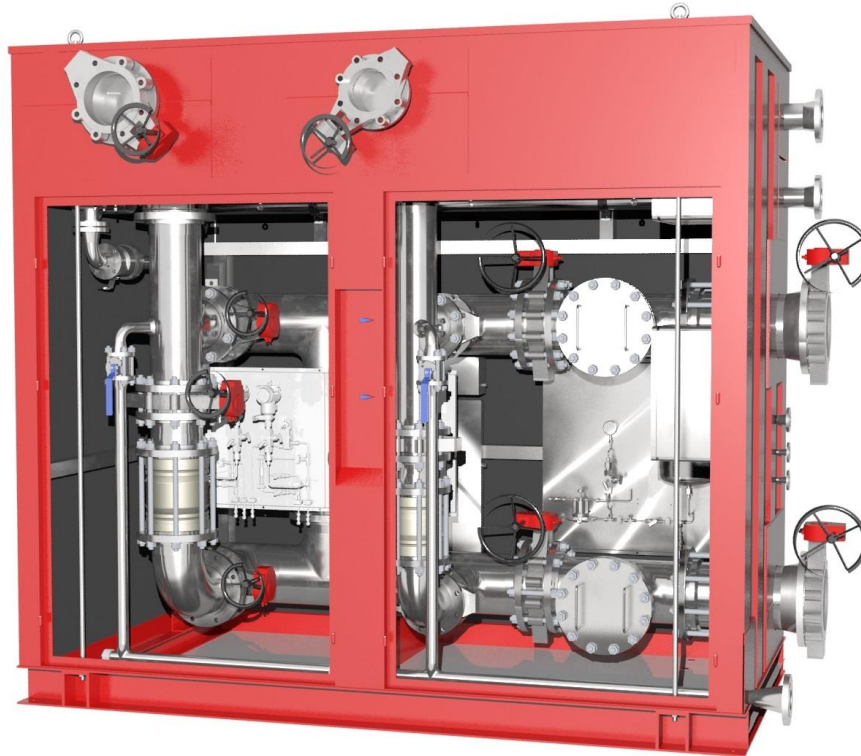

PRODUCT DESCRIPTION:

DESIGN LAYOUT:

Double valve Deluge Foam skid

Two Separate Firewater inlets
Internal manual bypass valves at each deluge valve
Reduced size flow test/drain arrangement for firewater only
Turbine drive foam proportioners
Foam in Main and by-pass mode
Inlet strainers

STANDARD MATERIALS:

Skid enclosure:	AISI 316L.
Water Piping/Valves:	Titanium
Foam Piping/Valves:	AISI 316

ALTERNATIVE MATERIALS:

Piping:	CuNi 90/10, Super Duplex
Valves:	Super Duplex, BS1400 AB2/LG2.

WORKING PRESSURE:

20 barg

FPE AS
PO Box 142
N-4065 Stavanger
Norway

Office Address :
Kanalarmen 12,
N-4033 Stavanger

E-mail: post@fpe.no

Telephone : 51 95 92 92
Faximile :51 95 92 91
Enterprise No: 981 990 374
QA Certificate no: 2001-OSL-AQ-7140



DELM-FP-01 Double valve deluge foam skid

System logic drawing

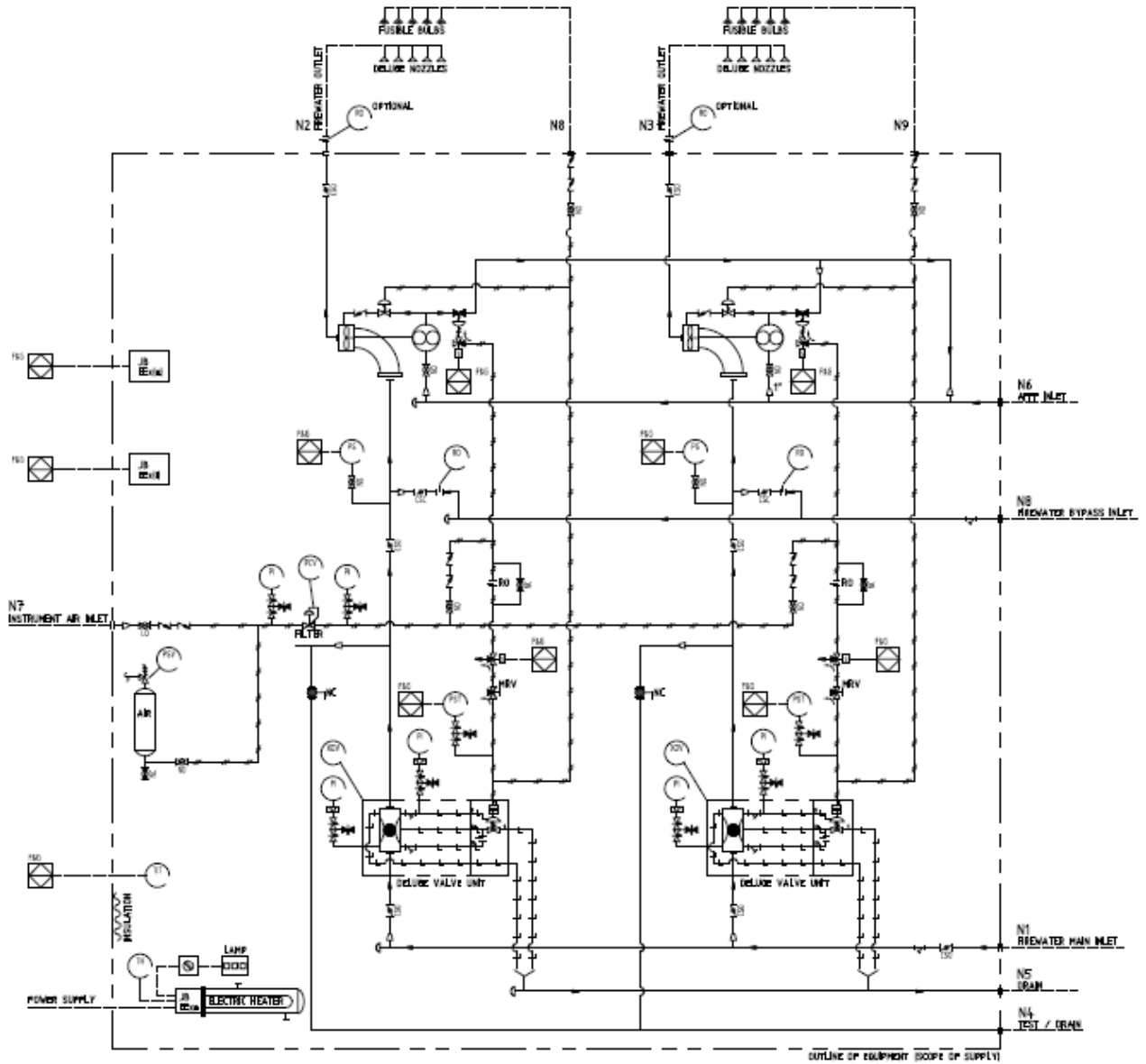

FPE AS
 PO Box 142
 N-4065 Stavanger
 Norway

Office Address :
 Kanalarmen 12,
 N-4033 Stavanger

E-mail: post@fpe.no

Telephone : 51 95 92 92
 Faximile : 51 95 92 91
 Enterprise No: 981 990 374
 QA Certificate no: 2001-OSL-AQ-7140

